

Product data sheet

Specifications

SQUARE D



[TAA] Mini circuit breaker,
Homeline, 50A, 2 pole,
120/240VAC, 10kA AIR, ground
fault class A, plug in, UL

HOM250GF1

Main

Product	Miniature circuit-breaker
Range	Homeline
Current Rating	50 A
Certifications	UL Listed
Voltage Rating	120/240 V AC
Mounting Type	Plug-in
Number of Poles	2P
Short Circuit Current Rating	10 kA
Number of Spaces	2
Circuit Breaker Type	Ground fault protecting class A 6 mA
Ratings	HACR rated
Electrical Connection	Screw clamp terminals
Wire Size	1 x AWG 12...AWG 4 (aluminium) 1 x AWG 14...AWG 6 (copper)

Complementary

Tightening torque	40.7 lbf.in (4.6 N.m) 0.004...0.02 in ² (2.5...10 mm ²) (AWG 16...AWG 14) 40.7 lbf.in (4.6 N.m) 0.006...0.03 in ² (4...20 mm ²) (AWG 12...AWG 4)
Height	3.13 in (79.50 mm)
Width	2 in (50.8 mm)
Depth	2.98 in (75.69 mm)

Environment

Ambient Air Temperature for Operation	104 °F (40 °C)
---------------------------------------	----------------

Ordering and shipping details

Category	US1DE3D00147
Discount Schedule	DE3D
GTIN	785901783572
Returnability	Yes

Country of origin	MX
-------------------	----

Packing Units

Unit Type of Package 1	PCE
------------------------	-----

Number of Units in Package 1	1
------------------------------	---

Package 1 Height	3.60 in (9.144 cm)
------------------	--------------------

Package 1 Width	2.20 in (5.588 cm)
-----------------	--------------------

Package 1 Length	5.40 in (13.716 cm)
------------------	---------------------

Package 1 Weight	19.520 oz (553.382 g)
------------------	-----------------------

Unit Type of Package 2	CAR
------------------------	-----

Number of Units in Package 2	33
------------------------------	----

Package 2 Height	5.60 in (14.224 cm)
------------------	---------------------

Package 2 Width	13.80 in (35.052 cm)
-----------------	----------------------

Package 2 Length	21.20 in (53.848 cm)
------------------	----------------------

Package 2 Weight	40.550 lb(US) (18.393 kg)
------------------	---------------------------

Unit Type of Package 3	PAL
------------------------	-----

Number of Units in Package 3	1584
------------------------------	------

Package 3 Height	40.00 in (101.600 cm)
------------------	-----------------------

Package 3 Width	40.00 in (101.600 cm)
-----------------	-----------------------

Package 3 Length	48.00 in (121.920 cm)
------------------	-----------------------

Package 3 Weight	1947.0008 lb(US) (883.144 kg)
------------------	-------------------------------

Contractual warranty

Warranty	Lifetime
----------	----------

Sustainability

Green Premium™ label is Schneider Electric's commitment to delivering products with best-in-class environmental performance. Green Premium promises compliance with the latest regulations, transparency on environmental impacts, as well as circular and low-CO₂ products.

Guide to assessing product sustainability is a white paper that clarifies global eco-label standards and how to interpret environmental declarations.

[Learn more about Green Premium >](#)

[How we assess product sustainability >](#)



Transparency

Well-being performance

✓ Mercury Free

✓ Rohs Exemption Information [Yes](#)

Reach Regulation [REACH Declaration](#)

Eu Rohs Directive Compliant with Exemptions

China Rohs Regulation [China RoHS declaration](#)
Product out of China RoHS scope. Substance declaration for your information.

Environmental Disclosure [Product Environmental Profile](#)

Circularity Profile [End of Life Information](#)

California Proposition 65 WARNING: This product can expose you to chemicals including: DINP, which is known to the State of California to cause cancer, and DIDP, which is known to the State of California to cause birth defects or other reproductive harm. For more information go to www.P65Warnings.ca.gov

Technical Illustration

Dimensions

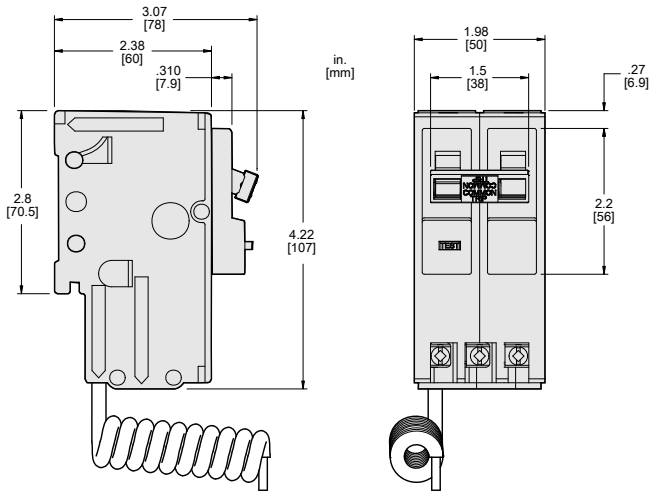

All dimensions are approximate.
Also refer to technical drawings and documentation.

Technical Illustration

Wiring diagram

Typical Wiring / Alambrado típico / Câblage typique

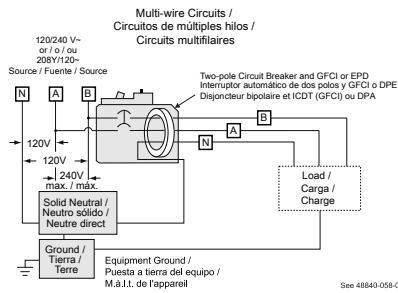
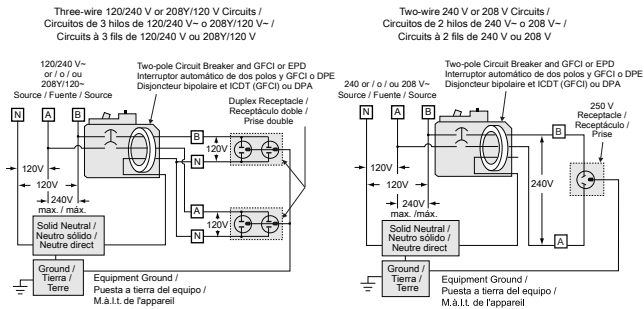

Image of product / Alternate images

Alternative

Technical Benefits
GFCI Circuit Breaker

