



### R4000 DRY SERIES BATTERY

#### ELECTRICAL SPECIFICATIONS

Nominal Voltage	6 V
Capacity @ C100	239 Ah
Capacity @ C20	225 Ah
Capacity @ C10	198 Ah
Capacity @ C5	185 Ah
Capacity @ 75A	124 min
Capacity @ 25A	475 min
Energy @ C100	1434 Wh
Internal Resistance	1.74 mΩ
Short Circuit Current	4300 A
Self Discharge	<3% per Month

#### CHARGE SPECIFICATIONS

Recommended Charge Current	20 - 45 A
Maximum Charge Current	55 A

#### CHARGE VOLTAGES

Charge Stage	12 V System	24 V System	36 V System	48 V System
Bulk/Absorption	14.4 V - 14.7 V	28.8 V - 29.4 V	43.2 V - 44.1 V	57.6 V - 58.8 V
Float	13.6 - 13.8 V	27.2 - 27.6 V	40.8 - 41.4 V	54.4 - 55.2 V

#### CHARGE TEMPERATURE COMPENSATION

Cold Temperature Charging	+2.8 mV/cell/°F	+5 mV/cell/°C
Hot Temperature Charging	-2.8 mV/cell/°F	-5 mV/cell/°C

#### DIMENSIONAL SPECIFICATIONS

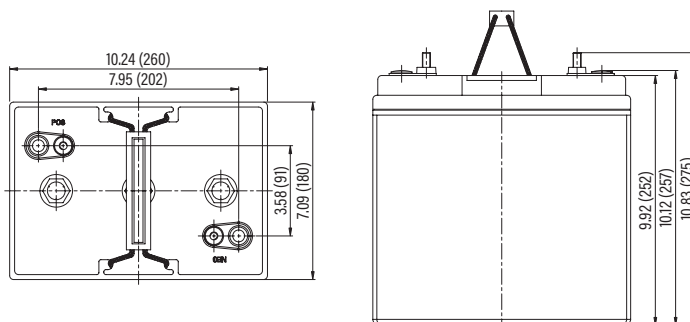

#### MECHANICAL & PHYSICAL SPECIFICATIONS

Dimensions (L x W x H)	10.24 x 7.09 x 10.79" 260 x 180 x 274 mm
Weight	66 lbs (30 kg)
Terminal Type	AP & 5/16" Stud
Terminal Torque AP	44 - 62 in-lbs (5 - 7 N-m)
Terminal Torque STUD	120 - 180 in-lbs (14 - 20 N-m)
Battery Type	VRLA
Case Material	Polypropolyene
Handle	Rope with plastic grip

#### TEMPERATURE SPECIFICATIONS

Operation/Storage Temperature Range	-4 - 122 °F (-20 - 50 °C)
-------------------------------------	---------------------------

#### COMPLIANCE SPECIFICATIONS

Certifications	UL1989
Shipping Classification	UN 2800, CLASS 8





### PERFORMANCE CHARACTERISTICS

