



R4000 DRY SERIES BATTERY

ELECTRICAL SPECIFICATIONS

Nominal Voltage	12 V
Capacity @ C100	119 Ah
Capacity @ C20	115 Ah
Capacity @ C10	110 Ah
Capacity @ C5	97 Ah
Capacity @ 75A	65 min
Capacity @ 25A	242 min
Energy @ C100	1428 Wh
Internal Resistance	4.45 mΩ
Short Circuit Current	3400 A
Self Discharge	<3% per Month

CHARGE SPECIFICATIONS

Recommended Charge Current	12 - 23 A
Maximum Charge Current	29 A

CHARGE VOLTAGES

Charge Stage	12 V System	24 V System	36 V System	48 V System
Bulk/Absorption	14.4 V - 14.7 V	28.8 V - 29.4 V	43.2 V - 44.1 V	57.6 V - 58.8 V
Float	13.6 - 13.8 V	27.2 - 27.6 V	40.8 - 41.4 V	54.4 - 55.2 V

CHARGE TEMPERATURE COMPENSATION

Cold Temperature Charging	+2.8 mV/cell/°F	+5 mV/cell/°C
Hot Temperature Charging	-2.8 mV/cell/°F	-5 mV/cell/°C

DIMENSIONAL SPECIFICATIONS

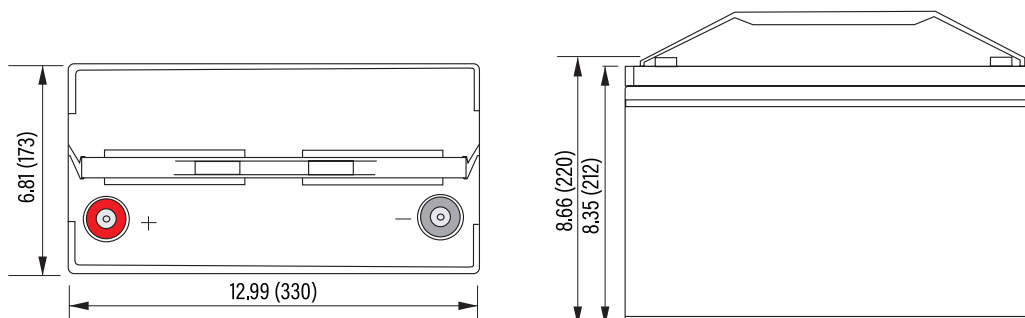

MECHANICAL & PHYSICAL SPECIFICATIONS

Dimensions (L x W x H)	13.0 x 6.8 x 8.7"
	330 x 173 x 220 mm
Weight	67.5 lbs (30.6 kg)
Terminal Type	AP & 5/16" Stud
Terminal Torque AP	44 - 62 in-lbs (5 - 7 N-m)
Terminal Torque STUD	120 - 180 in-lbs (14 - 20 N-m)
Battery Type	VRLA
Case Material	ABS
Handle	Plastic

TEMPERATURE SPECIFICATIONS

Operation/Storage Temperature Range	-4 - 122 °F (-20 - 50 °C)
-------------------------------------	---------------------------

COMPLIANCE SPECIFICATIONS

Certifications	UL1989
Shipping Classification	UN 2800, CLASS 8





PERFORMANCE CHARACTERISTICS

