

# GS-IOB-120/240VAC

## Input/Output/Bypass Assembly

## Installation Instructions

### Purpose

This document provides information on how to install the Input/Output/Bypass Assembly needed for a 120/240 Vac configuration using an OutBack GSLC (GS Load Center) enclosure.

This product allows manual switching between a single Radian Series Inverter/Charger and an AC source, facilitating maintenance and power continuity. It is intended to be installed within the GSLC or one of its variants.

### Scope

This document covers how to install the input, output, and bypass circuit breakers and mechanical interlock onto the GSLC. **Wiring requirements are site-specific and will vary by installation.** Certain steps may be omitted or altered if they do not apply to a particular installation.

*These instructions are for use by qualified personnel who meet all local and governmental code requirements for licensing and training for the installation of electrical power systems with AC and DC voltage up to 600 volts.*

### Requirements

OutBack Power's GS-IOB-120/240VAC is intended as a component for OutBack listed UL508A or UL1741 Industrial Control Panels, specifically the GSLC variants. It is intended for indoor use only. This equipment is to be installed by qualified personnel only. Refer to the *GS Load Center Installation Manual* for complete installation instructions.

### Grounding Instructions

The enclosure for the GS-IOB-120/240VAC should be connected to a grounded, permanent wiring system. The AC and DC circuits are not bonded to the enclosure chassis. System grounding, when required by the National Electric Code, ANSI/NFPA 70 or the Canadian Electrical Code, CSA C22.1, is the responsibility of the installer. All installations should comply with all national and local codes and ordinances.

The equipment ground is marked with this symbol: 

# GS-IOB-120/240VAC Installation Instructions

## Tools Required

- Philips Screwdriver
- Flat Screwdriver
- Socket Set
- Digital multimeter (DMM) or ohmmeter

## Components



**Figure 1 GS-IOB-120/240VAC Components**

# GS-IOB-120/240VAC Installation Instructions

## Table 1 Parts List

Item	Quantity
AC Circuit Breakers, Double-Pole (50 A, 120/240 Vac) with 6-32 x 1/4" screws installed	4
Label Set	1
Installation Instructions	1
Hardware Kit:	
➤ Bus Bars	6
➤ Bus Bar Insulators, Red	6
➤ Bus Bar Insulators, Black	6
➤ Mechanical Bypass Plate, Red	1
➤ Mechanical Bypass Brackets, Red	2
➤ Self-Tapping Screws, 10-32 x 1/2"	13 (1 extra)
➤ Machine Screws, 6-32 x 3/8"	4
Conductors:	
➤ Wires, Labeled, Red and Black	12
➤ Wire, Labeled, White	1
➤ Wires, Short, Dual Ring Terminal, Red	2
➤ Wires, Short, Dual Ring Terminal, Black	2
➤ Wire, Green	1

## Installing the Bus Bars

The GS-IOB-120/240VAC has enough parts to install up to six AC bus bars in an enclosure. (The neutral and ground bars are already installed.) To install a bus bar in the GSLC:

1. Select one bus bar and two insulators of the same color (either red or black). Fit one insulator onto each end of the bus bar.
2. Insert one self-tapping 10-32 x 1/2" screws through the hole on each insulator. Seat these screws in the GSLC chassis and screw them in. These screws require a large amount of torque to start.
3. Apply the correct label from the label set to the chassis near each bus bar for identification purposes. Figure 2 shows the standard locations for these bus bars. Figure 5 on page 7 shows the intended label positions.

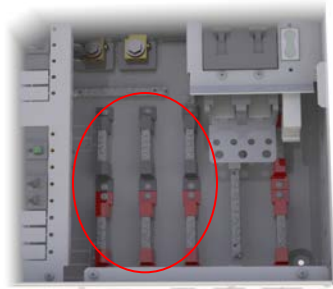

**Figure 2 Bus Bar Positions**



### IMPORTANT:

If the bus bars are placed in other locations or if the labels or electrical use of the bus bars differ from the figure, the wires included in this kit may not be of sufficient length.

## Installing the Circuit Breakers and Mechanical Bypass Assembly

The simplest method to install these devices is to remove the main circuit breaker bracket from the GSLC first. To remove the main bracket:

1. Remove the front cover (sometimes called the “front door”) of the GSLC. Open the door to 90 degrees and lift up about 1/2” to disengage it from the GSLC (see Figure 3).
2. Remove the interior cover (sometimes called the “dead front”) of the GSLC. Remove the six screws installed across the top and bottom of the cover (see Figure 3) and take the interior cover off.
3. Remove the main circuit breaker bracket. Remove the four screws at the top and bottom of the bracket (see Figure 3) and take it off.

**NOTE:** There may be star washers under some of these screws. These must be re-installed later to ensure proper grounding of the enclosure.

4. Remove the pre-installed screws in the circuit breakers before proceeding.

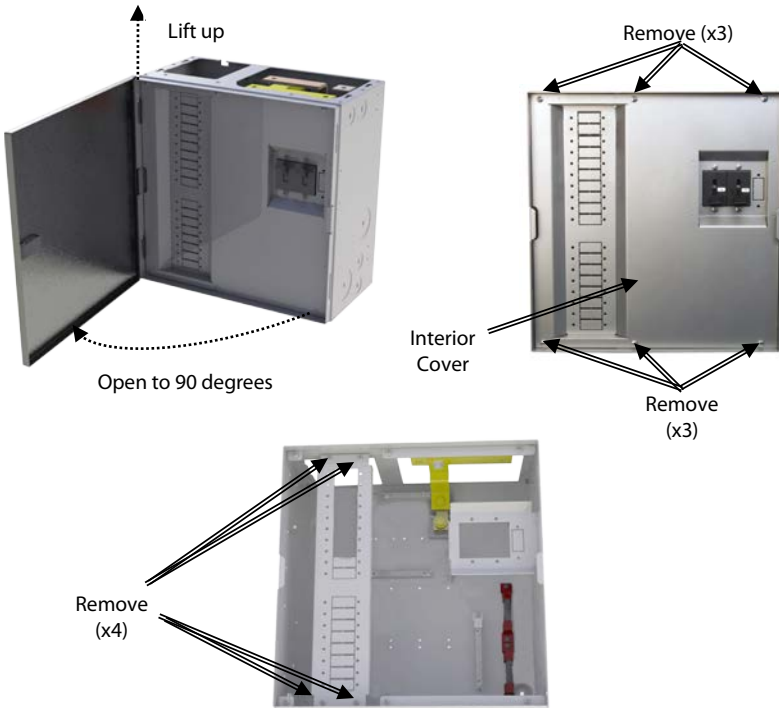
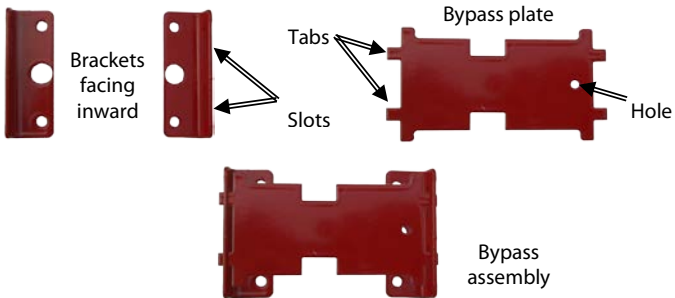

**Figure 3 Removing the Covers and Main Bracket**

## GS-IOB-120/240VAC Installation Instructions

Once the main bracket has been removed, install the circuit breakers and mechanical bypass according to the following steps.

1. Place each circuit breaker behind the bracket and orient it so that the pole with the switch is on top and the numbers read correctly. Center the device so that the raised area protrudes through the bracket.
2. Place the red bypass brackets over the screw holes for the top three circuit breaker poles. Face the brackets inward as shown in Figure 4.
3. While placing the red brackets, insert the red bypass plate between them. The tabs on the plate should fit into the slots on the brackets. **NOTE:** The plate must be oriented so the hole is on the right. Both circuit breakers covered by the plate must be in the OFF position.
4. When the circuit breakers and bypass mechanism is in place, insert screws through the holes in the main bracket. Use the 6-32 x 3/8" screws to secure the breakers with red brackets. Use the screws previously removed from the circuit breakers to reattach those not covered by the red brackets.
5. Tighten until secure, but do not over-tighten.



### Figure 4 Installing Mechanical Bypass

Once installed, the plate will not allow both circuit breakers to be in the ON position. The plate can slide to allow one device to be turned on. The upper circuit breaker allows the inverter's output to deliver power normally to the loads. The lower one causes the AC source to bypass the inverter directly to the loads.

## Basic AC Wiring

The GS-IOB-120/240VAC comes with six red, six black, and one white wire that are labeled according to their intended electrical connection. It also comes with an unlabeled green wire, and four unlabeled short red and black wires. If the preceding steps are followed, as well as the drawing in Figure 5, these wires will have sufficient length to make the intended connections.

It is recommended that the wires be connected to the circuit breakers prior to re-installing the main circuit breaker bracket. To install the wires:

1. Remove the nut and washers from each circuit breaker, noting the sequence of the washers.
2. For each of the 12 wires, install the wire's ring terminal on the appropriate terminal post for each circuit breaker according to Figure 5. Typically each post is equipped with two identical star washers. The ring terminal on the wire should be installed between these star washers. If there is only one star washer, install the ring terminal on the post first, then the star washer and the remaining hardware.
3. Torque the nut to 35 in-lbs (4 Nm).
4. Install the 4 short wires between the input, output, and bypass circuit breakers as shown in Figure 5.
5. Re-install the main circuit breaker bracket using the four screws and any star washers that were previously removed. Use the illustrations in Figure 3 on page 4 for reference.
6. Connect the 12 wires from each circuit breaker to the appropriate bus bar as shown in Figure 5.
7. Connect the white AC Neutral wire to the neutral bus bar.
8. Connect the green wire to the ground bus bar.

All wires from steps 6, 7, and 8 should be torqued to 25 in-lbs (2.8 Nm). It is recommended to make 90-degree bends in the wires as shown, so that the layout is easy to follow in the future. (The wires have been designed to be long enough.)

At this time, all wires should be connected to bus bars or circuit breakers. Certain wires will only have one end connected, with the other end meant to be connected to a 120/240 Vac Radian Series Inverter/Charger. (This is usually positioned above the GSLC.) The disconnected wires should have these labels:

- AC OUT HOT LEG 1
- AC OUT HOT LEG 2
- GRID IN HOT LEG 1
- GRID IN HOT LEG 2
- GEN IN HOT LEG 1
- GEN IN HOT LEG 2
- AC NEUTRAL
- (Green Wire – No Label)

Before connecting these wires to the inverter, use a digital multimeter to check that all electrical connections are correct and show continuity. Once confirmed, connect the wires to the Radian inverter/charger, removing knockouts and

## GS-IOB-120/240VAC Installation Instructions

installing bushings as necessary. Refer to the installation manuals for the Radian inverter and the GSLC for additional wiring instructions.

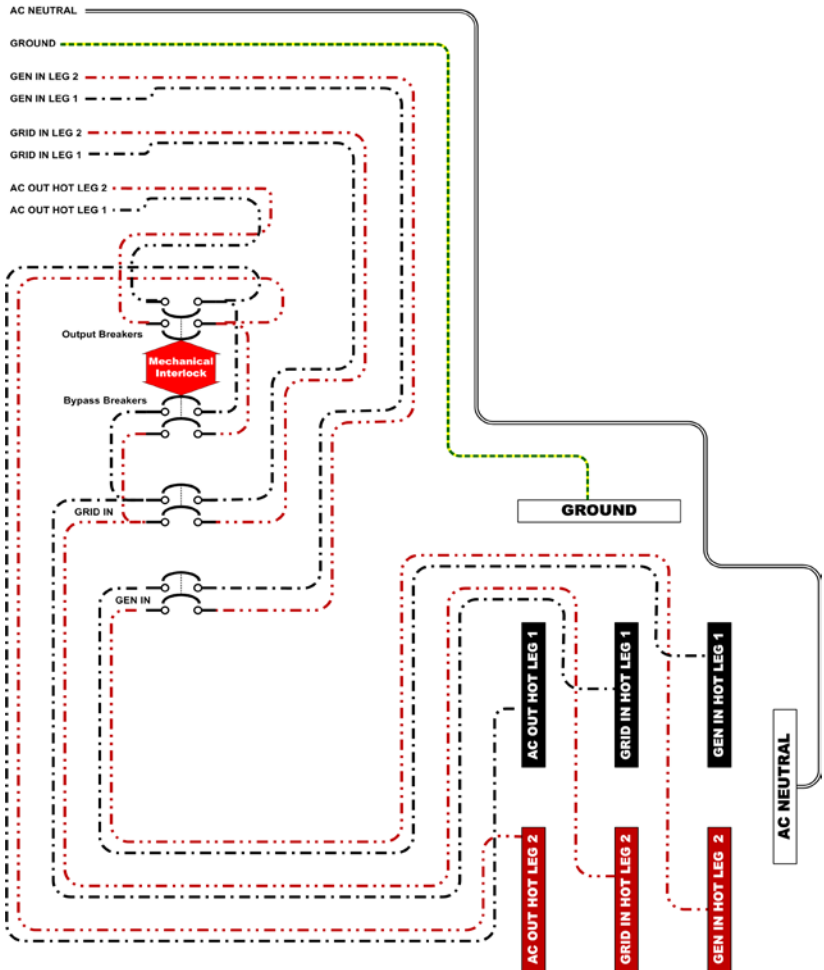

**Figure 5 Basic AC Wiring**

At this stage, the installation is complete. The interior cover must be re-installed using the six screws and star washers previously removed. The front cover can then be re-installed. Use the illustrations in Figure 3 on page 4 for reference.

There may be a label on the inside of the front cover that identifies the circuit breakers and their usage. The label set included with this kit can be used to mark the circuit breakers that were just installed.

## About OutBack Power Technologies

OutBack Power Technologies is a leader in advanced energy conversion technology. Our products include true sine wave inverter/chargers, maximum power point tracking charge controllers, and system communication components, as well as circuit breakers, accessories, and assembled systems.

### Disclaimer

UNLESS SPECIFICALLY AGREED TO IN WRITING, OUTBACK POWER TECHNOLOGIES:

(a) MAKES NO WARRANTY AS TO THE ACCURACY, SUFFICIENCY OR SUITABILITY OF ANY TECHNICAL OR OTHER INFORMATION PROVIDED IN ITS MANUALS OR OTHER DOCUMENTATION.

(b) ASSUMES NO RESPONSIBILITY OR LIABILITY FOR LOSS OR DAMAGE, WHETHER DIRECT, INDIRECT, CONSEQUENTIAL OR INCIDENTAL, WHICH MIGHT ARISE OUT OF THE USE OF SUCH INFORMATION. THE USE OF ANY SUCH INFORMATION WILL BE ENTIRELY AT THE USER'S RISK.

### Notice of Copyright

GS-IOB-120/240VAC Installation Instructions© February 2014 by OutBack Power Technologies. All Rights Reserved.

### Trademarks

OutBack Power is a registered trademark of OutBack Power Technologies.

### Date and Revision

September 2011, Revision A

### Part Number

900-0126-01-00 REV A



North America  
5917 – 195<sup>th</sup> St N.E., #7  
Arlington, WA USA