

## GROUNDING MID CLAMP

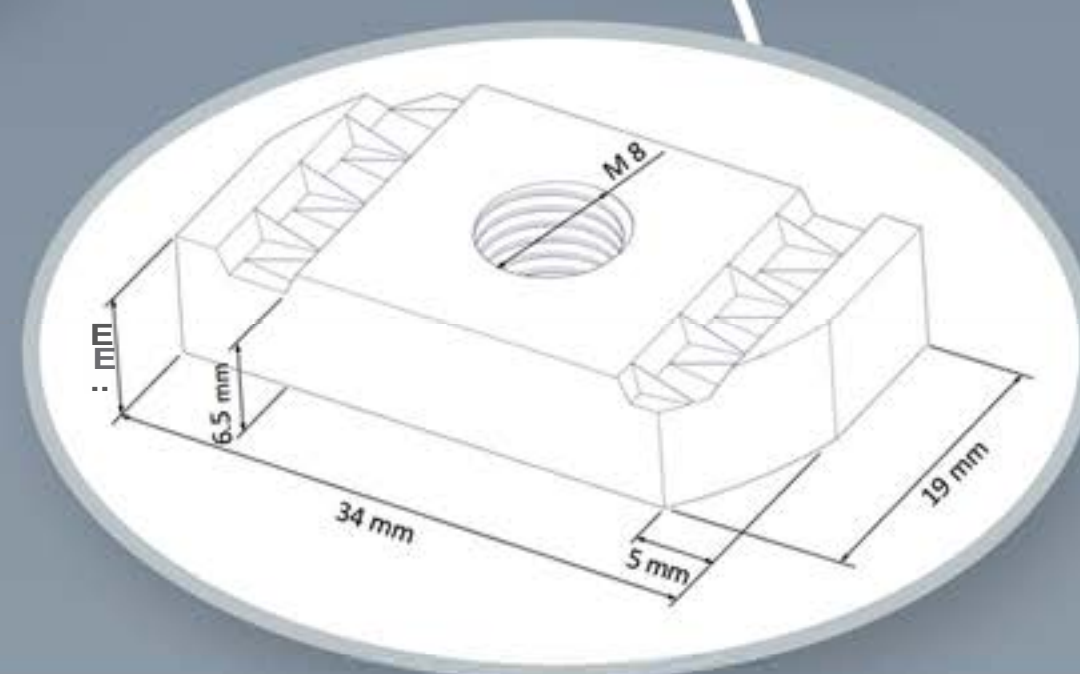
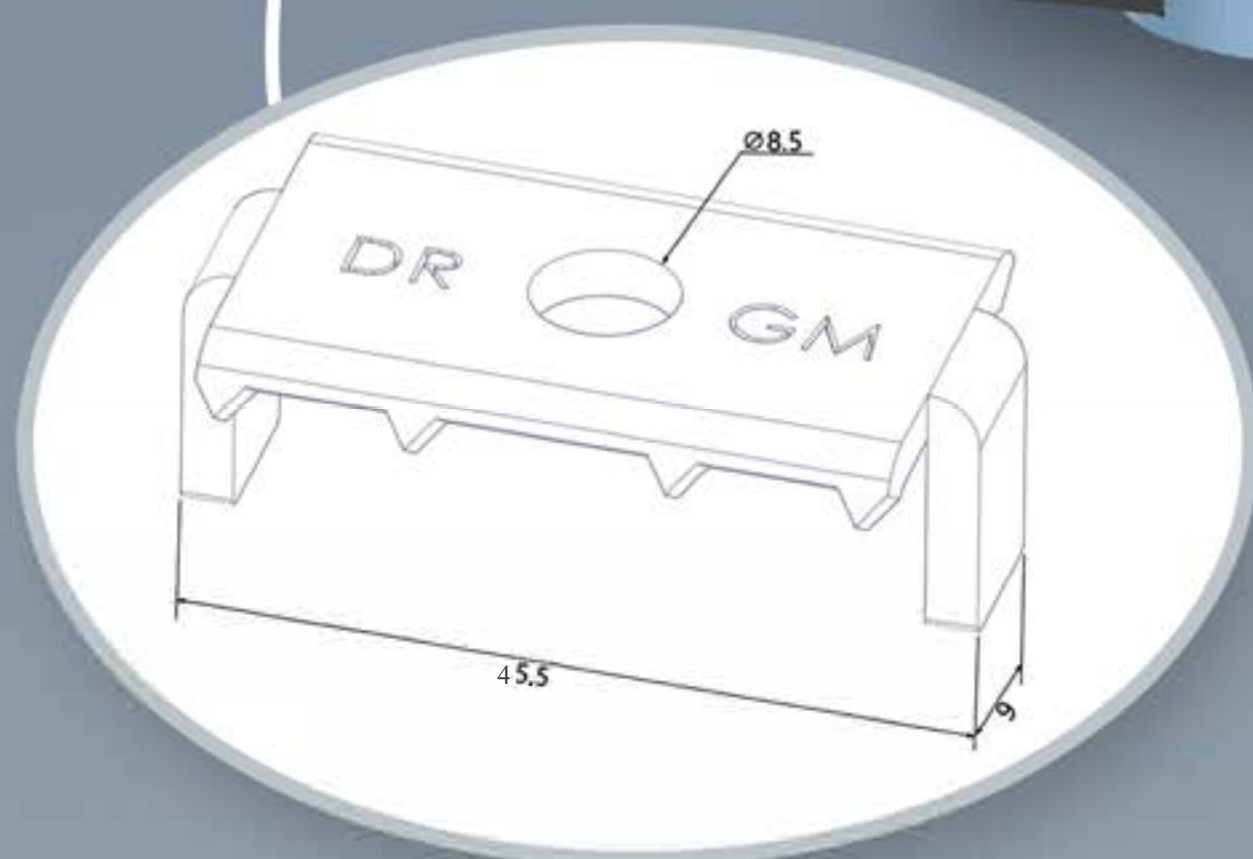
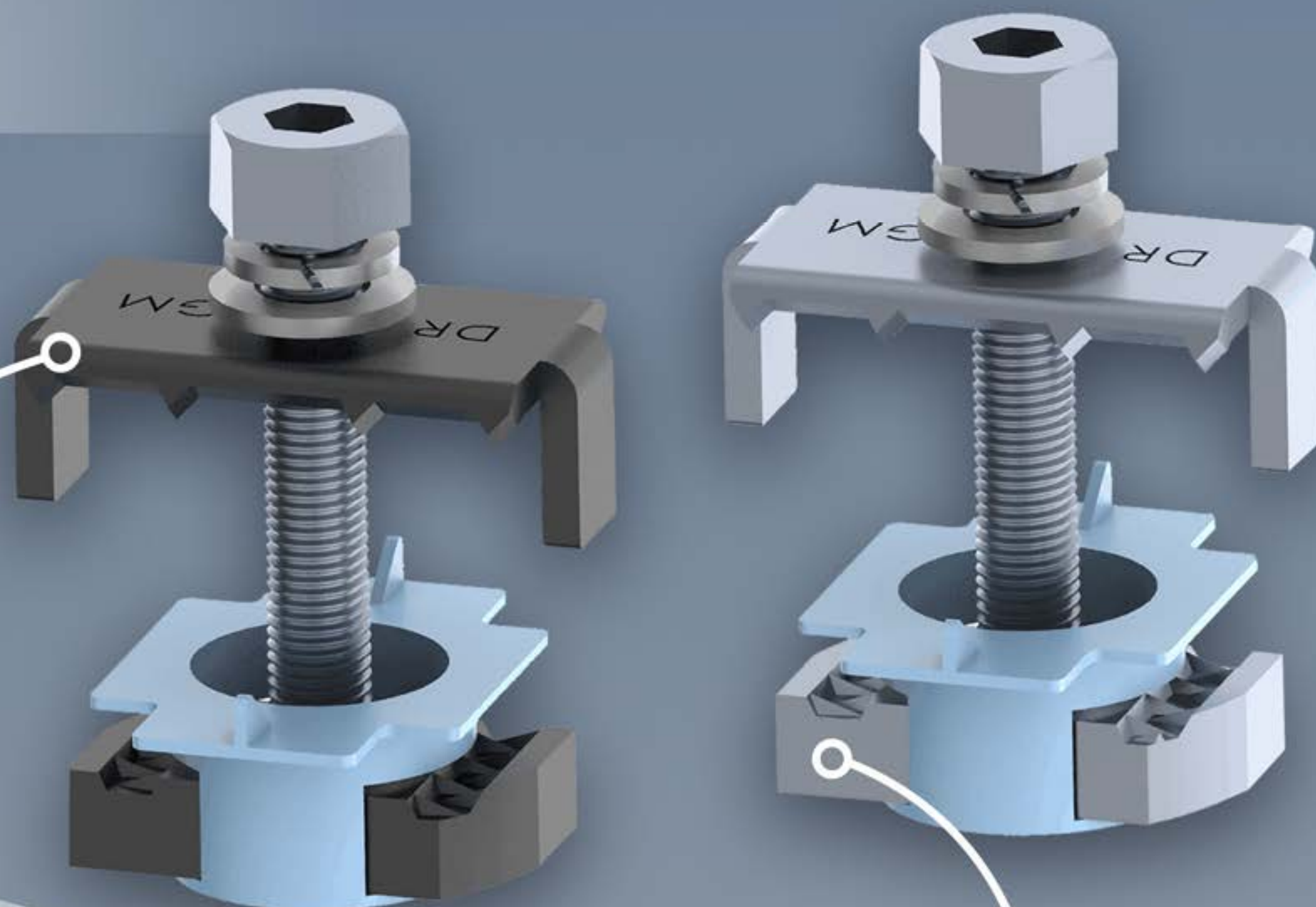

## SECURE BRILLIANCE

Dual Rack Grounding Mid Clamp, a pivotal component that seamlessly penetrates the anodized coating of solar module frames, establishing a secure electrical bond that permeates the entire array. Our Grounding Mid Clamp, boasting an advanced design, delivers unwavering reliability in grounding both 60-cell and 72-cell Type 1/2/3 solar module frames, validated through rigorous testing and certification under UL 2703 standards.

Dual Rack integrated grounding system creates multiple parallel grounding paths throughout the array, enhancing safety for system owners. This innovative design includes the Grounding Mid Clamp and the three-in-one stainless steel Grounding Lug (GBS-P6, UL467) for grounding, bonding, and splicing—all in a single unit. Choose Dual Rack for a groundbreaking approach to solar module grounding, where safety meets efficiency, and reliability is paramount.

## ADVANTAGES AND HIGHLIGHTS

- Advanced Dual Rack Design
- Compatible with DR Mounting System
- Installation Simplicity
- Time and Cost Savings
- Efficient Design
- Versatile Installation
- User Friendly
- Multiple Options and Aesthetics
- 20-year Limited Warranty
- Conforms to UL STD 2703
- ETL Certified
- Class A Fire Rated





# PRODUCT SELECTION AND ITEM CHART

## Component List

Material	QTY
Mid Clamp	01
Channel Strut	01
MS Dual Hex Bolt	01
Lock Washer	01
Channel Strut Floater (Blue Plastic)	01

## Product Line

Item#	Product Name
DR-GMC-01	DR Grounding Mid Clamp-Clear
DR-GMC-02	DR Grounding Mid Clamp-Black



## Ordering Specifics

	Package	Small Box	Big Box
Standard Package	10pcs	80pcs	320pcs
Weight	1.67 lbs	13.36 lbs	53.44 lbs

## INSTALLATION GUIDE

*For detailed instructions please refer to the Dual Rack installation guide*

Dual Rack proudly presents its versatile Mid Clamps, standing as a testament to our commitment to innovative photovoltaic (PV) module mounting solutions. Building upon the legacy of our renowned rails, the Dual Rack Mid Clamps offer robust and durable support for solar installations on both roof and ground PV projects. These Mid Clamps exemplify strength and reliability, maintaining the industry-leading standards set by Dual Rack.

Our Mid Clamps seamlessly integrate into the overall Dual Rack system, ensuring a streamlined and efficient installation process. With the same commitment to competitive pricing and quality assurance, Dual Rack provides a comprehensive solution for solar module mounting needs. Pre-stamped structural certifications are readily available, simplifying compliance with regulatory standards in various states. Experience the ease of installation, reduced costs, and unparalleled flexibility that define Dual Rack's approach to solar module mounting, where reliability meets innovation.

### GROUNDING MID CLAMP



#### 1. Install the Grounding Mid Clamp:

Insert the Grounding Mid Clamp Channel Strut parallelly into the Dual Rack Rail channel using the blue Channel Strut Floater for support.

#### 2. Secure Channel Strut:

Lock the Channel Strut in the Dual Rack Rail channel by turning the Channel Strut Floater 180 degrees, aligning the grooves with the rail channel lip.

#### 3. Verify Channel Strut Placement:

Confirm secure placement of the Channel Strut in the rail channel by checking the parallel position of the Channel Strut Floater. Position module(s) under the Grounding Mid Clamp, aligning the teeth with the module frame.

#### 4. Ensure Electrical Continuity:

Confirm electrical grounding continuity by ensuring the Grounding Mid Clamp teeth are securely in contact with the module frames. Use an M8 bolt (10 ft.-lb. torque recommended) to fasten, allowing the Channel Strut to align with the Dual Rack Rail grooves.

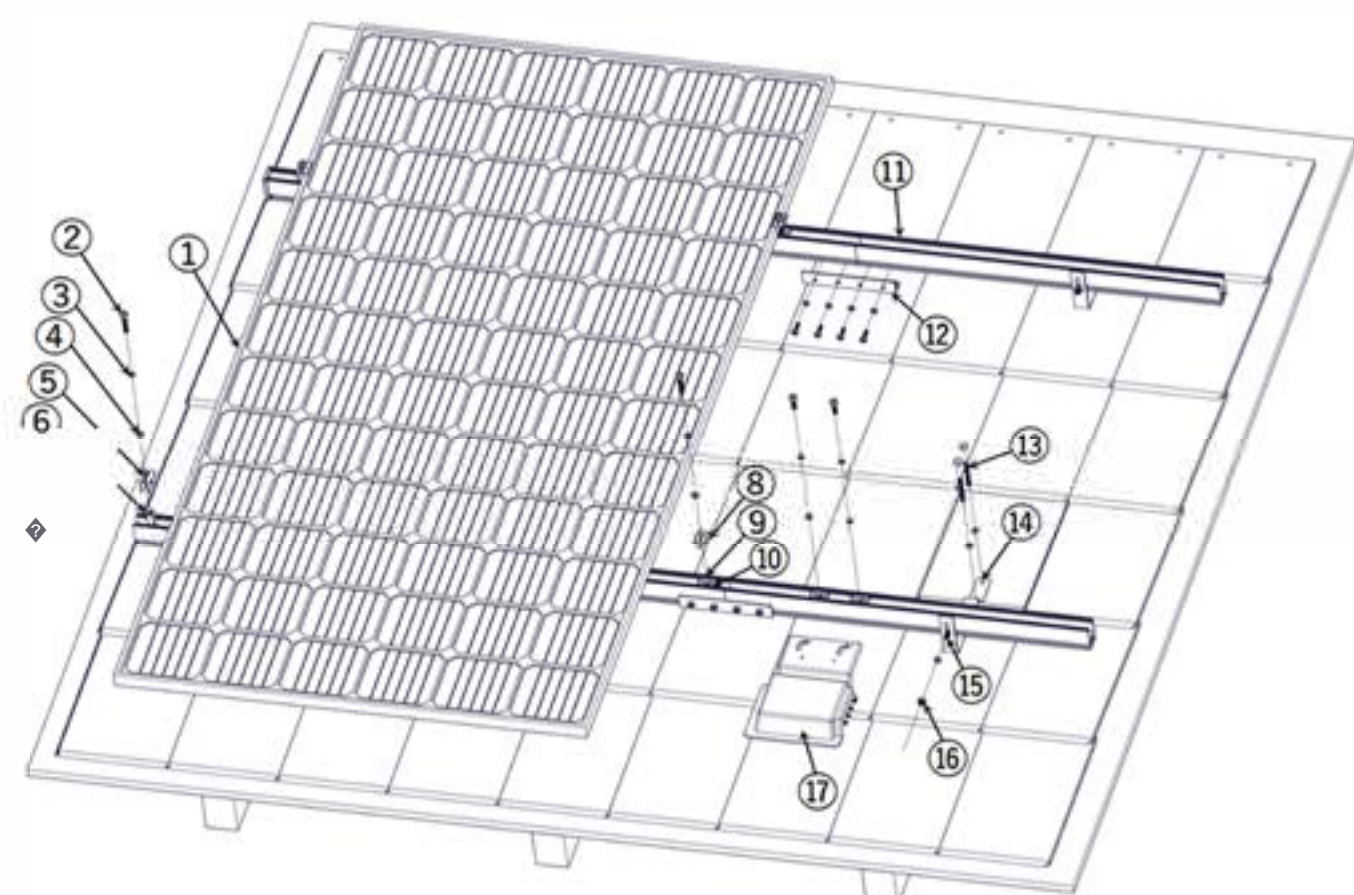

- ⊙ Solar Panel
- ⊙ Channel Strut Base
- ⊙ Dual Hex Bolt
- ⊙ Standard Rail
- Ⓜ Lock washer
- ⊙ Splice Bar
- ⊙ Flat washer
- Ⓜ Flash L Kit-5 Inch Lag Bolt
- ⊙ Universal End Clamp Top
- ⊙ Flat Tile Roof Hook
- Ⓜ Universal End Clamp Base
- Ⓜ T-Bolt
- Ⓜ Standard Rail End-Cap
- Ⓜ Flange Nut
- ⊙ Mid Clamp Top
- Ⓜ Inverter
- Ⓜ Channel Strut Floater

• End Clamp, Mid Clamp and Channel Strut are pre-assembled and can be detached as top, base and other accessories such as washer and floater showing in the installation guide.



Dual Rack Inc.  
2290 Agate Ct., Unit A-B, Simi Valley, CA, 93065  
www.DualRack.net

Email: info@DualRack.net  
Phone: +1 (805) 254 - 2250

