

CHANNEL STRUT

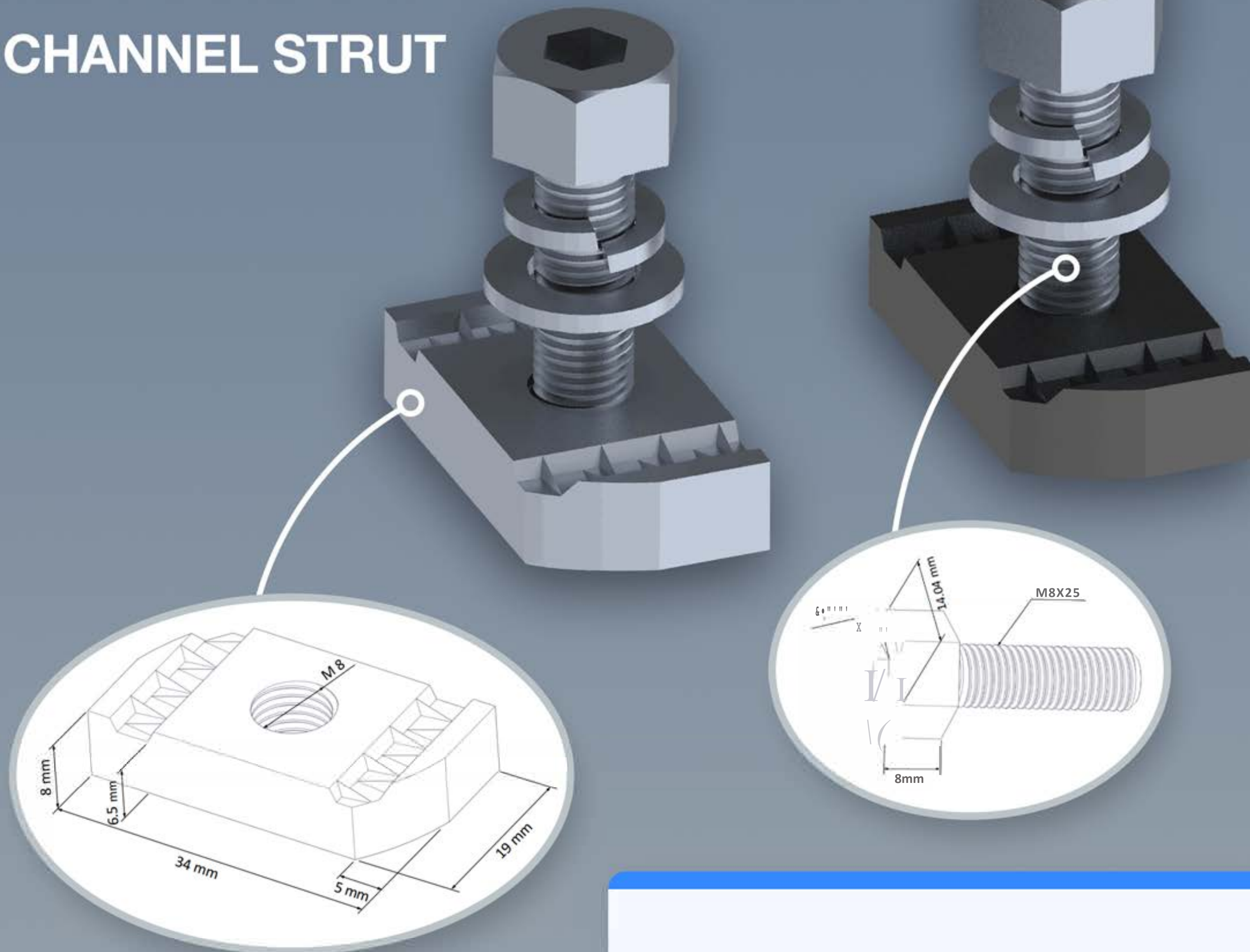

SECURE BRILLIANCE

Dual Rack Channel strut is made with precision design and accuracy, using telescoping end pieces which eliminates the need for custom cuts. The Dual Rack Channel Strut works with most standard frame micro inverters, no matter the thickness (one-size-fits-all micro inverters strut). With the Dual Rack high quality Channel Strut there's no need for welding and punching which makes it a flexible installation. The Dual Rack Channel Strut is made from stainless steel whose strength and durability have been field-tested in installations across the United States. Available both in black and clear finish.

ADVANTAGES AND HIGHLIGHTS

- Advanced Dual Rack Design
- Compatible with DR Mounting System
- Installation Simplicity
- Time and Cost Savings
- Efficient Design
- Versatile Installation
- User Friendly
- Multiple Options and Aesthetics
- 20-year Limited Warranty
- Conforms to UL STD 2703
- ETL Certified
- Class A Fire Rated



PRODUCT SELECTION AND ITEM CHART

Product Line	
Item #	Product Name
DR-CCS-01	DR Channel Strut- Clear
DR-BCS-01	DR Channel Strut- Black



Ordering Specifics			
Standarg Package	Package 10pcs	Small Box 80pcs	Big Box 320pcs
Channel Strut	0.64 lbs	Weight 5.12lbs	20.48 lbs

Component List	
Material	QTY
Channel Strut Set	
Channel Strut	01
MS Dual Hex Bott	01
Star washer	01
Flat washer	01

INSTALLATION GUIDE

*For detailed instructions please refer to the Dual Rack installation guide

Dual Rack introduces its Channel Strut, extending its legacy of robust, long-life photovoltaic (PV) module mounting solutions for both roof and ground PV projects. Representing a pinnacle in strength, the Dual Rack Channel Strut upholds the reputation set by our rails which are known for both its strength and competitive pricing. Pre-stamped structural certifications are readily available in most states, streamlining regulatory processes. Installation remains simple and swift, translating to reduced installation costs. True to our commitment to flexibility, Dual Rack allows modules to be mounted in both landscape and portrait orientations, providing versatile options for your solar project configuration.

CHANNEL STRUT

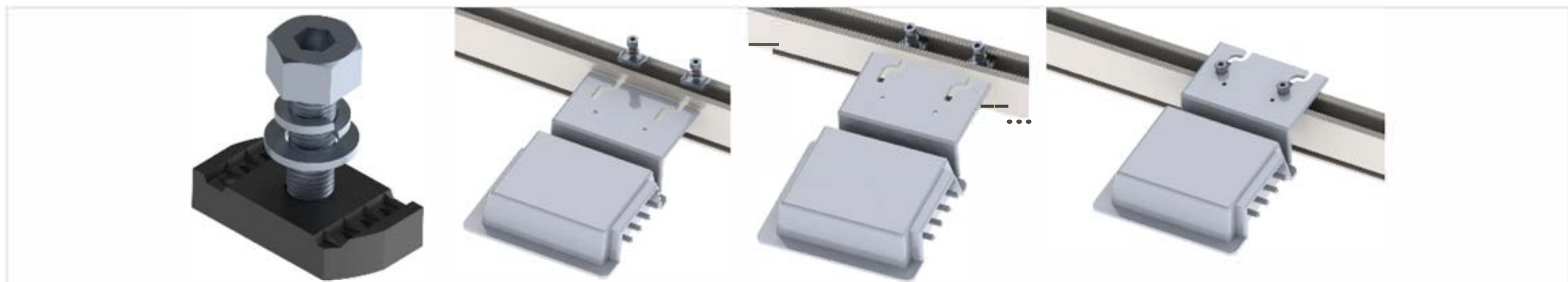

1. Secure the Channel Strut:

Insert the 3/8" Allen bolt through the washer and attach it securely to the channel strut.

2. Position the Channel Strut:

Lower or slide the channel strut through the rail gap, ensuring precise alignment with the rail system.

3. Install Micro Inverter:

Place the micro inverter between the rail and washer, positioning it accurately within the assembly.

4. Final Attachment:

Screw in the 3/8" bolt, allowing the channel strut to align seamlessly with the rail grooves. Verify that all components are securely fastened for a reliable installation.

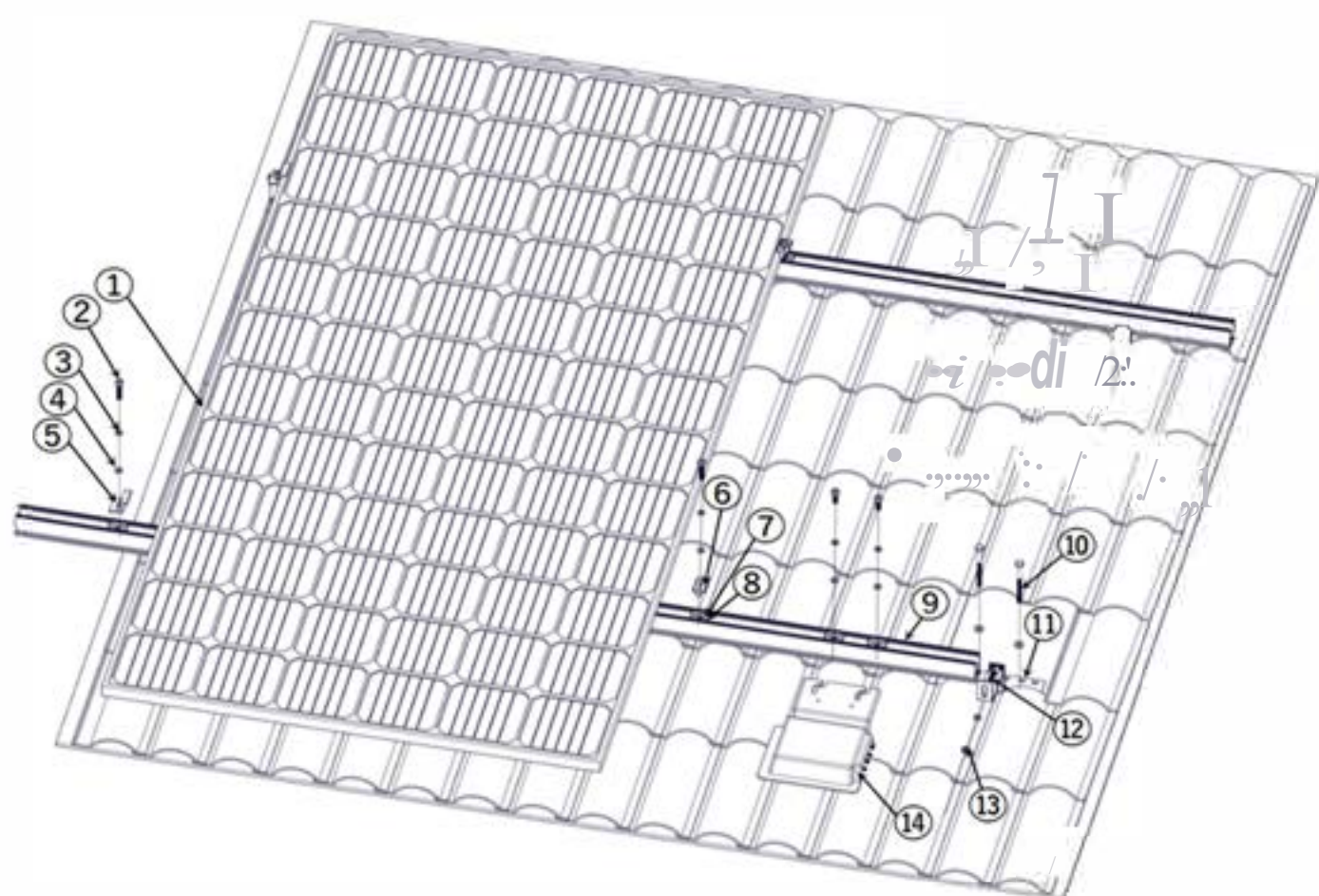

- Ⓢ Solar Panel
- Ⓢ Dual Hex Bolt
- Ⓢ Lock washer
- Ⓢ Flat washer
- Ⓢ End Clamp Top
- Ⓢ Mid Clamp Top
- Ⓢ (1) Channel Strut Floater
- Ⓢ Channel Strut Base
- Ⓢ Standard Rail
- Ⓢ Flash L Kit-5 Inch Lag Bolt
- Ⓢ S-Tile Hook-Adjustable
- Ⓢ T-Bolt
- Ⓢ Flange Nut
- Ⓢ Inverter

* End Clamp, Mid Clamp and Channel Strut are pre-assembled and can be detached as top, base and other accessories such as washer and floater showing in the installation guide.



Dual Rack Inc.
2290 Agate Ct. Unit A-B, Simi Valley, CA, 93065
www.DualRack.net

Email: info@DualRack.net
Phone: +1 (805)254 - 2250

