

# 17962

17660

BLACK SPLIT TOP QB2 WITH 3" MICROFLASHING®  
FOR ASPHALT, EPDM, & TPO ROOFS  
PATENT # 8448407

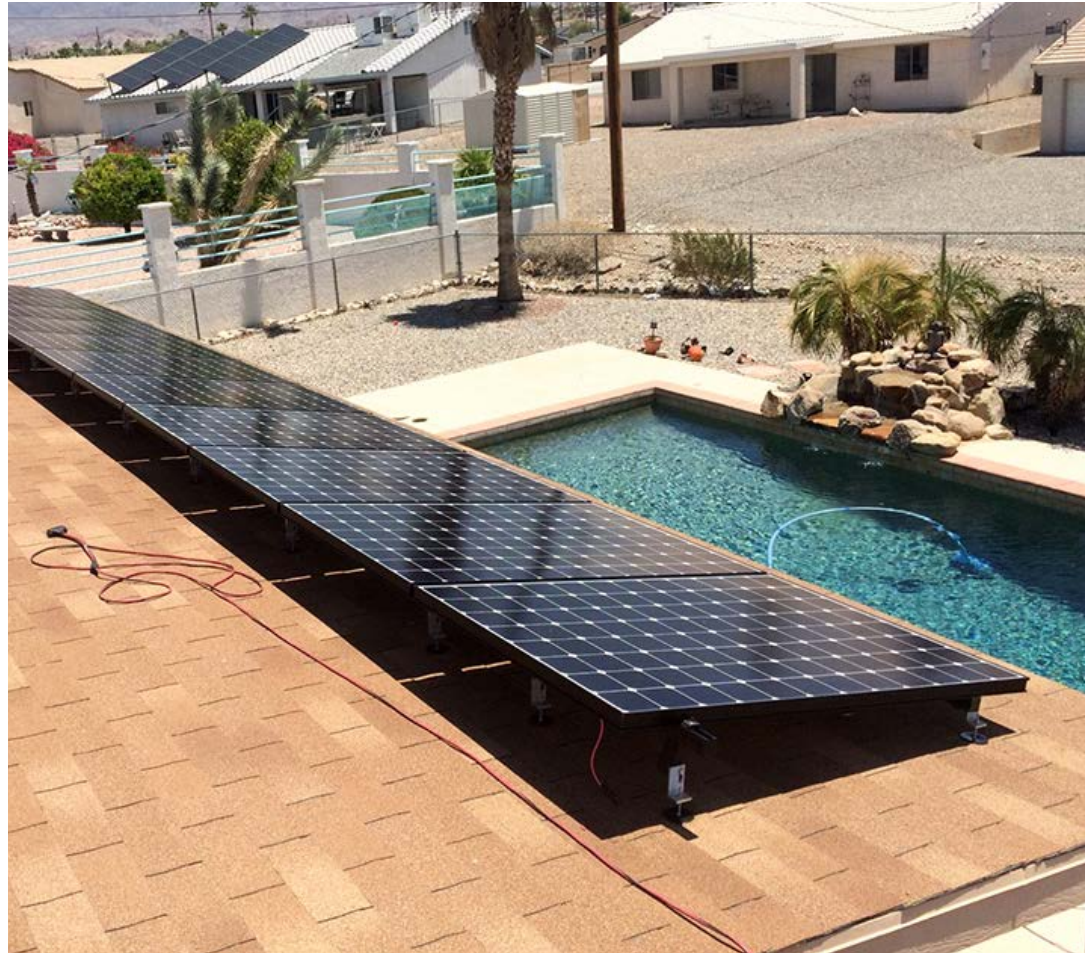

# SPEC SHEET

Part #	Box Quantity
17660	4" QB2 (25)
17962	3" Microflashing® (25); 4" QB2 (25); Black Split Top L-Foot (25)



**QB2**

PN# 17660

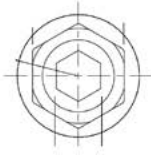

Dual Drive Technology  
1/2" Hex Outer Drive  
6mm Inner Drive

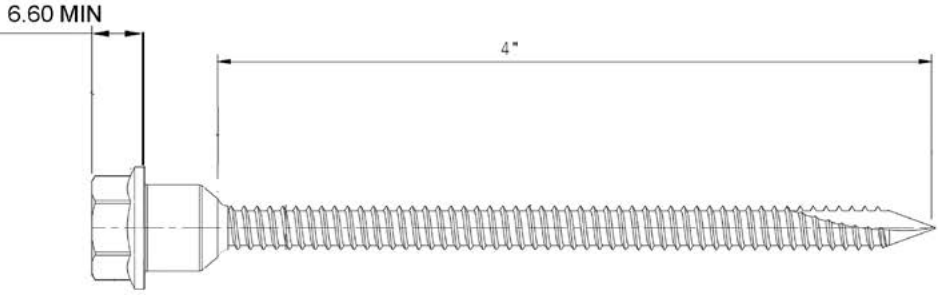

MATERIAL: Stainless Steel 304				STATUS: Approved
SURFACE TREATMENT: PASSIVATION		NAME:	DATE:	
TOLERANCE: AS PER DRAWING		DRAWN:	MAR. 19'19	DRAWING NO: SL20190316-1
		APPROVED:	MAR. 19'19	
VERSION: 01		FORMAT: A3	Scale: 5:1	SALES:
ISO:		PAGES: 1/1	UNIT: METRIC	

PN# 17961

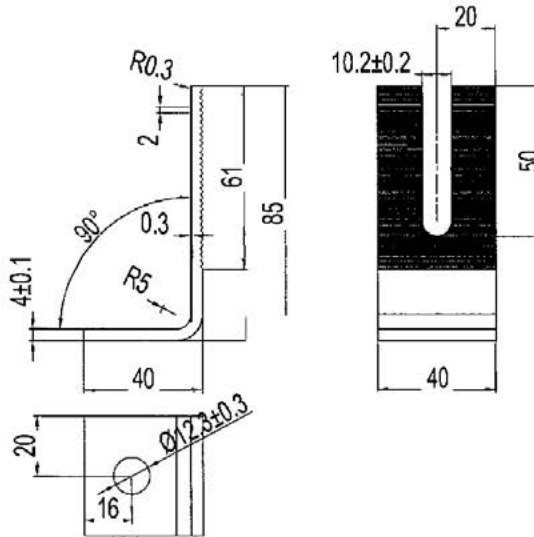

Baiting tolerance	±2 mm
Hole tolerance	±0.5 mm
Hole distance tolerance	±0.5 mm
Form tolerance	±2 mm
Thickness tolerance	±0.1 mm
Angle tolerance	±1°

*2/14/21*

Design		Scale	Quantity
Drawing		Material	SUS304
Confirm		17661 Split Top	Drawing No.
Verify			Finish

Part # 17669

5/16" x 3"  
304 Stainless Steel  
**Compression Washer Black**

